

Our range of KEIL assembly aids offers measuring devices such as depth control guides and feeler gauges for controlling the drill hole geometry as well as screw drivers, torque wrenches, tool sets and further carefully selected work and machine accessories.

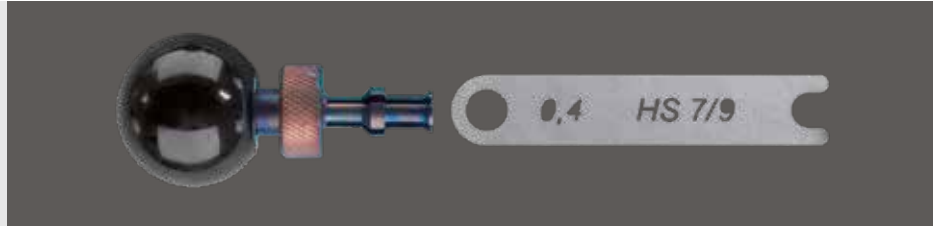

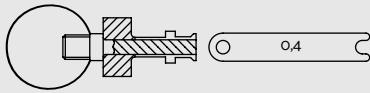

Product information

Checking the undercut hole

▶ With this measuring device all significant dimensions of the drill hole are inspected, the insertion depth is set and the life time of the façade drill bit is monitored. Every KEIL undercut anchor has its **own depth control guide** with feeler gauge.

h_s = insertion depth [mm]	D1 = drill hole \varnothing [mm]	h_z = [mm]	article no.
4.0	7.0	0.5	585 100 040
5.5	7.0	0.8	585 100 055
7.0	7.0	0.8	585 100 070
8.0*	8.0	0.5	585 100 080
8.5	7.0	0.8	585 100 085
10.0	7.0	0.8	585 100 100
11.5	7.0	0.8	585 100 115
13.0	7.0	0.8	585 100 130
15	7.0	1.3	585 100 150
20.0	9.0	1.5	585 102 200

Usage

- ▶ Inspection of the undercut hole.
- ▶ Monitoring of the life time of the façade drill bits.

Possible applications

- ▶ Depth control guide fitting for the insertion depth of the undercut anchor.

Accessories

- ▶ Washer for depth control guide (p. 59)

Design



Depth control guide with feeler gauge

Note

- ▶ For measuring undercut holes in uneven panel back sides we recommend using the 3 mm washer in combination with a 3 mm longer depth control guide.
- ▶ * depth control guide for square anchor

Instructions for use

- ▶ Use according to inspection instruction and according to approval and depth control guide information. (p. 57)

Nord LB, Magdeburg, DE © KEIL



Inspection of the undercut hole

For inspecting all significant dimensions of the drill hole, setting the insertion depth and monitoring the life time of the façade drill bits. Every KEIL undercut anchor has its own depth control guide with feeler gauge.

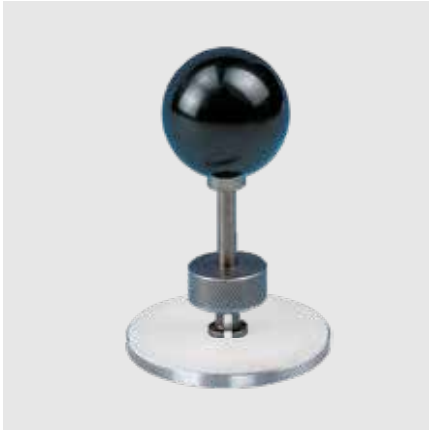

Place base of depth control guide in undercut drill hole.

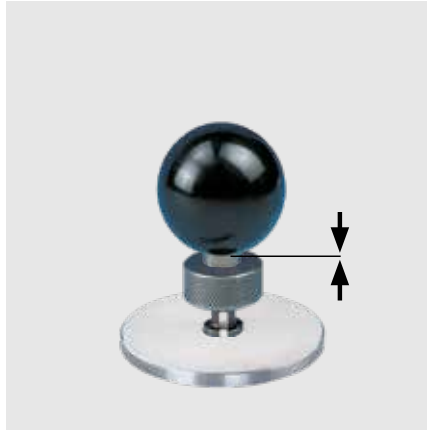

Inspection 1: insert bolt to stop.

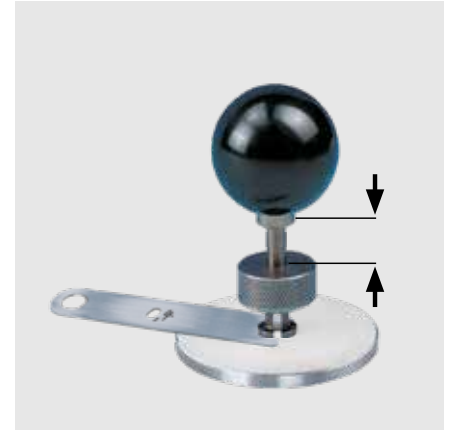

Inspection 2: push in feeler gauge between panel and depth control guide base. If the bolt now **cannot** be pushed in to the base, the drill hole is in order.

Not properly executed drillings

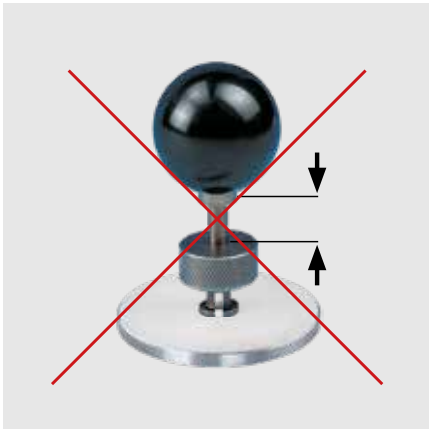

Depth control guide cannot be inserted without feeler gauge.

Error:

Drill hole too deep or lack of undercut.

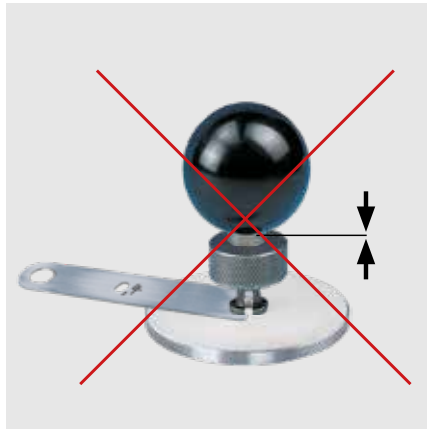

Depth control guide can be pushed to stop although feeler gauge has been inserted.

Error:

Drill hole not deep enough.

Depth control guide geometry

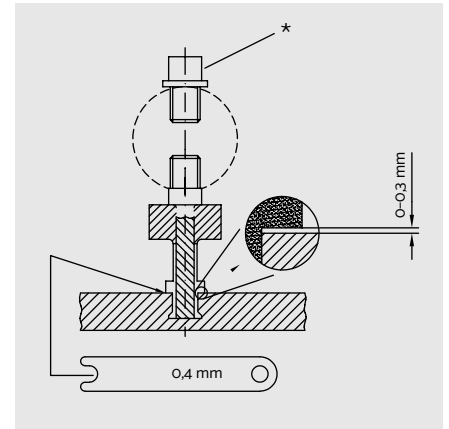

*optional tester for max. cylindrical drill hole diameter (alternatively internal cylindrical gauge)

Control of depth control guide (simple and fast control by user)

- ▶ Monitoring of the undercut diameter via fitted hole in the sensor.
- ▶ Insert base of depth control guide into the fitted hole in the sensor.
- ▶ Push in bolt to stop.
- ▶ If the depth control guide can now be pulled out of the drill hole, it will need to be replaced.



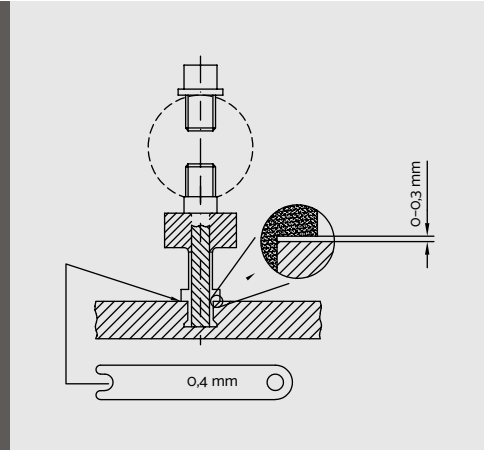

article no.
585 100 001

Usage

- ▶ In connection with depth control guide ($h_s + 3 \text{ mm}$)

Possible applications

- ▶ For façade panels with textured back sides

Design

Stainless steel washer for depth control guide

- ▶ Thickness 3 mm, \varnothing 40 mm

Product information

- ▶ For textured back sides of façade panels (e.g. made of ceramics). The washer generates a reference surface for setting the insertion depth h_s .
- ▶ As the washer is 3 mm thick, a bigger depth control guide with a 3 mm longer insertion depth needs to be employed.
- ▶ The measuring process for the inspection of the undercut hole will proceed as described for the depth control guide, placing the feeler gauge between washer and depth control guide.

Example:

For an insertion depth of $h_{sp} = 7 \text{ mm}$ within the panel using the 3 mm washer, a depth control guide with an insertion depth $h_s = 10 \text{ mm}$ needs to be employed.

Tribunal Judicial de Base, Macau © MCM



ASSEMBLY AIDS

Torque wrench 1–6 Nm



article no.
585 300 122

Application

- ▶ For the assembly with controlled torque value.
- ▶ According to approval 2.5–4 Nm

Design

- ▶ With adjusting scale
- ▶ SW 8
- ▶ With hex wrench socket

Torque screwdriver 3.0 Nm



article no.
585 300 121

Application

- ▶ For the assembly with controlled torque value

Accessories

- ▶ Wrench sockets DIN 3126 E6.3 (p. 61)

Design

- ▶ With replacement bit 6.3 (1/4" bit holder)
- ▶ Power grip with non-slip surface
- ▶ Preset torque value 3.0 Nm

Cordless screw driver with controlled torque value



Product information

- ▶ The General Building Approval and the European Technical Assessment (Approval) amongst other things regulate the tightening torque of the screws for the assembly of the KEIL undercut anchors. Their demands are as follows: "The assembly of the anchor must be carried out with only one screwdriver, which has to be set to a tightening torque of $2.5 \text{ Nm} \leq T_{\text{inst}} \leq 4.0 \text{ Nm}$ "
- ▶ This assembly with controlled torque value is possible with appropriately equipped cordless screwdrivers. Those should have verifiable machine and process capability.
- ▶ Suppliers for screwdrivers of this sort, also with preset torque value, can be provided upon request.



Explanations on the torque value

Basically, the KEIL undercut anchor is an anchor with a "displacement-controlled assembly". For the segments to fit snugly into the undercut, they have to be "folded out" with the aid of a screw or a threaded pin. The high assembly safety of the KEIL system is demonstrated by the fact that this is only possible with correctly undercut drillings. A restriction of the tightening torque value will ensure that mistakes are recognized even for incorrect drillings or too short undercut anchors and that the assembly will be safe at all times.

Tool set



article	spanner gap
tool set consisting of:	
special open-ended spanner	SW 9
screwdriver with 1/4" holder	
wrench socket, DIN 3126 E6.3	SW 8
wrench socket, DIN 3126 E6.3	SW 10
screw driver bit	SW 3
screw driver bit	TX 30
Allen key	SW 3
article no.: 585 300 200	

Design

special open-ended spanner

- ▶ flat open-ends spanner for anchor assembly

Screw driver with 1/4" holder

- ▶ With telescopic blade
- ▶ Quick release holder
- ▶ With three-component handle

Wrench socket,

DIN 3126 E6.3

- ▶ For hex bolts and nuts

Screw driver bit

- ▶ Drive DIN 3126 C6,3
- ▶ For threaded pins resp. anchor screws

Allen key

- ▶ DIN 911
- ▶ For threaded pins

Screw-in tool for stud bolts



Product information

- ▶ The screw-in tool limits the screw-in depth of a threaded pin into an undercut anchor.
- ▶ The threaded pin is inserted into the tool and screwed into the undercut anchor up to the stop.
- ▶ The integrated hinge in the screw-in tool ensures that the threaded pin remains in position in the undercut anchor when the tool is unscrewed from the pin.
- ▶ This ensures that the threaded pin is mounted flush with the tip of the undercut anchor. The correct screw-in depth has to be monitored.
- ▶ The individual protrusion has to be determined for every combination of undercut anchor and threaded pin length.
- ▶ For further information please refer to the assembly instructions.

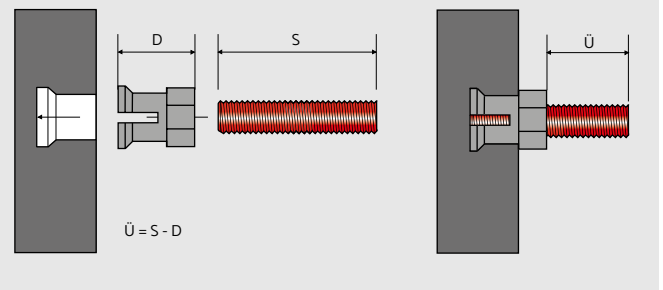

variant	article no.
Ü up to 18	585 300 010
Ü from 18	585 300 011

Design

- ▶ Assembly aid for undercut anchor BH with threaded pin.
- ▶ 1/4" bit drive DIN 3126 - E 6.3

Accessories

- ▶ Tool set (p. 61)

Note

- ▶ Please specify the insertion depth of the undercut anchor and the length of the threaded pin with your order.

Instructions for use

- ▶ The protrusion is to be determined individually according to the lengths of the undercut anchor and the threaded pin.
- ▶ Please observe KEIL assembly instructions for anchors.